

# MASTERBUILT®



## **MB20041124** Autolgnite™ Series 545

# Welcome | Bienvenue | Bienvenido |

Assembly images are shown first. Please read this entire manual before installation and use of this charcoal fuel burning appliance. Failure to follow these instructions could result in property damage, bodily injury or even death. Contact local building or fire officials about restrictions and installation inspection requirements in your area. Save these instructions.

A MAJOR CAUSE OF FIRES IS FAILURE TO MAINTAIN REQUIRED CLEARANCES (AIR SPACES) TO COMBUSTIBLE MATERIALS. IT IS OF UTMOST IMPORTANCE THAT THIS PRODUCT BE INSTALLED ONLY IN ACCORDANCE WITH THESE INSTRUCTIONS.

Les images de montage sont montrées en premier. Veuillez lire ce manuel au complet avant l'installation et l'utilisation de cet appareil au charbon de bois. Le non-respect de ces instructions pourrait entraîner des dommages matériels, des blessures corporelles ou même la mort. Prenez contact avec les responsables locaux de la construction ou des incendies pour connaître les restrictions et les exigences en matière d'inspection des installations dans votre région. Conservez ces instructions.

LE NON-RESPECT DES DÉGAGEMENTS (ESPACES LIBRES) REQUIS POUR LES MATÉRIAUX COMBUSTIBLES EST L'UNE DES PRINCIPALES CAUSES D'INCENDIE. IL EST EXTRÊMEMENT IMPORTANT D'INSTALLER CE PRODUIT CONFORMÉMENT À CES INSTRUCTIONS SEULEMENT.

Las imágenes de ensamblaje se muestran primero. Lea todo este manual antes de la instalación y uso de este artefacto de quema de combustible a carbón. Si no sigue estas instrucciones podrían producirse daños a la propiedad, lesiones corporales o incluso la muerte. Contacte al encargado de incendios o de su edificio local con respecto a las restricciones y requerimientos de inspección de la instalación en su área. Conserve estas instrucciones.

UNA DE LAS PRINCIPALES CAUSAS DE INCENDIO ES NO CONTAR CON EL ESPACIO DESPEJADO REQUERIDO (ESPACIOS LIBRES) FRENTE A LOS MATERIALES COMBUSTIBLES. ES DE PRIMORDIAL IMPORTANCIA QUE ESTE PRODUCTO SEA INSTALADO ÚNICAMENTE EN CONFORMIDAD CON ESTAS INSTRUCCIONES.

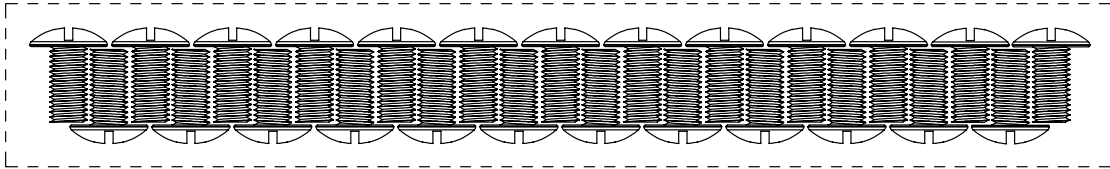

**A / 25**

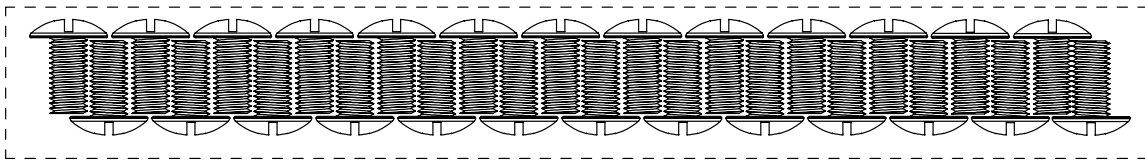

**A / 26**

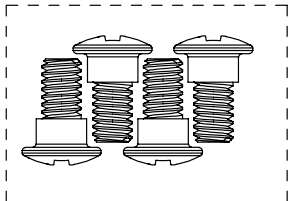

**B / 4**

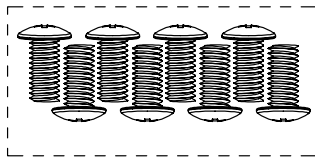

**C / 8**

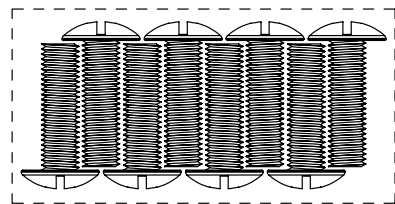

**D / 8**

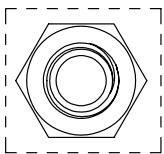

**E / 1**

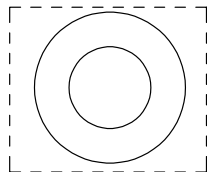

**F / 1**

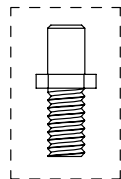

**G / 1**

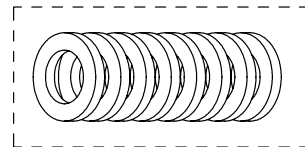

**H / 8**

# Parts Diagram | Schéma des pièces | Diagrama de partes

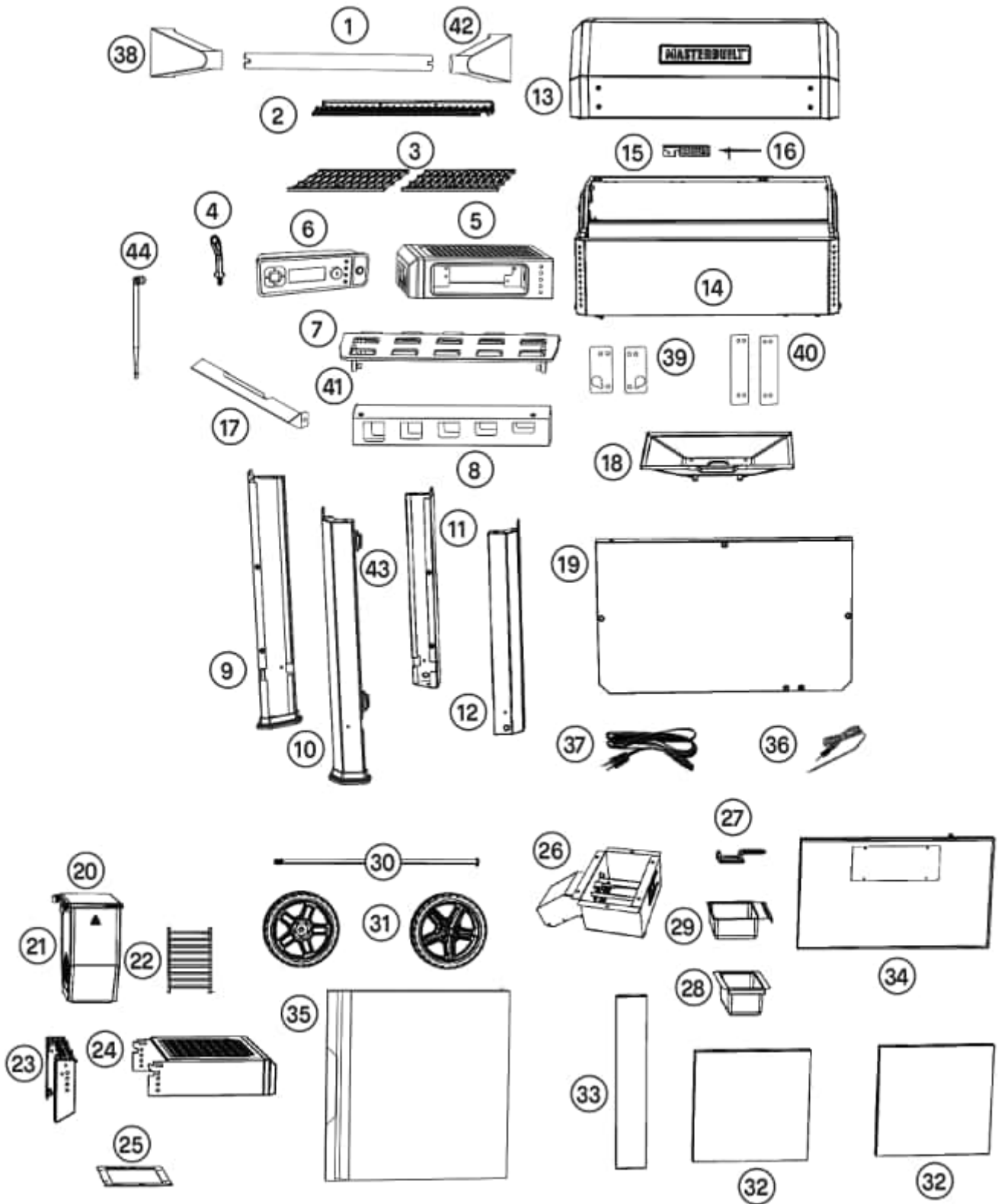

# Parts List

NO.	QTY.	DESCRIPTION	NO.	QTY.	DESCRIPTION
1	1	Lid Handle	23	1	Right Shelf Bracket
2	1	Warming Rack	24	1	Right Folding Shelf Assembly
3	2	Cooking Grates	25	1	Lower Hopper Gasket
4	1	Grate Lifter	26	1	Lower Hopper Assembly
5	1	Left Shelf Assembly	27	1	Firestarter Tray
6	1	Controller	28	1	Grease Tray
7	1	Heat Tent Assembly	29	1	Ash Tray
8	1	Heat Manifold	30	1	Axle with Lock Nut
9	1	Rear Left Leg	31	2	8" Wheels
10	1	Front Left Leg	32	2	Cart Side Panels
11	1	Rear Right Leg	33	1	Cart Front Panel
12	1	Front Right Leg	34	1	Cart Rear Panel
13	1	Lid Assembly	35	1	Cart Door Assembly
14	1	Body Assembly	36	1	Meat Probe
15	1	Temperature Probe Bracket	37	1	Power Cord
16	1	Temperature Probe	38	1	Lid Handle Bracket Left
17	1	Heat Manifold Support Bracket	39	1	Mica Strip Left Shelf
18	1	Grease Pan Assembly	40	1	Mica Strip Right Shelf
19	1	Bottom Shelf	41	2	Heat Manifold Bracket
20	1	Hopper Lid (Sear Plate)	42	1	Lid Handle Bracket Right
21	1	Mini Hopper	43	2	Magnetic Brackets
22	1	Charcoal Grate	44	1	Antenna

## BEFORE ASSEMBLY READ ALL INSTRUCTIONS CAREFULLY

- Assemble on a clean flat surface.
- Recommend assembling on cardboard to avoid residue on floors or scratches.
- Gloves recommended for assembly.
- Tools needed: Phillips head screwdriver, adjustable wrench, 19mm socket wrench.
- Approximate assembly time: 1 hour, 45 minutes.
- Recommend two people assemble to increase ease and reduce assembly time.
- Actual product may differ from picture shown.
- It is possible that some assembly steps have been completed in the factory.
- Remove all printed labels before use.

## DO NOT RETURN TO RETAILER!

For assembly assistance, missing or damaged parts, please contact Masterbuilt® Customer Service.

Masterbuilt® Premier Specialty Brands, LLC, 5367 New Peachtree Road, Suite 150, Chamblee, GA 30341

[www.masterbuilt.com/pages/customer-support](http://www.masterbuilt.com/pages/customer-support)

Masterbuilt® Kamado Joe Europe, Lange Voorhout 86, 2514 EJ, Den Haag, Netherlands

[international.masterbuilt.com/pages/customer-support](http://international.masterbuilt.com/pages/customer-support)

Masterbuilt® Kamado Joe UK Limited, Cheyenne House West Street, Farnham GU9 7EQ

[international.masterbuilt.com/pages/customer-support](http://international.masterbuilt.com/pages/customer-support)

Australia & New Zealand: Please contact your retailer

1

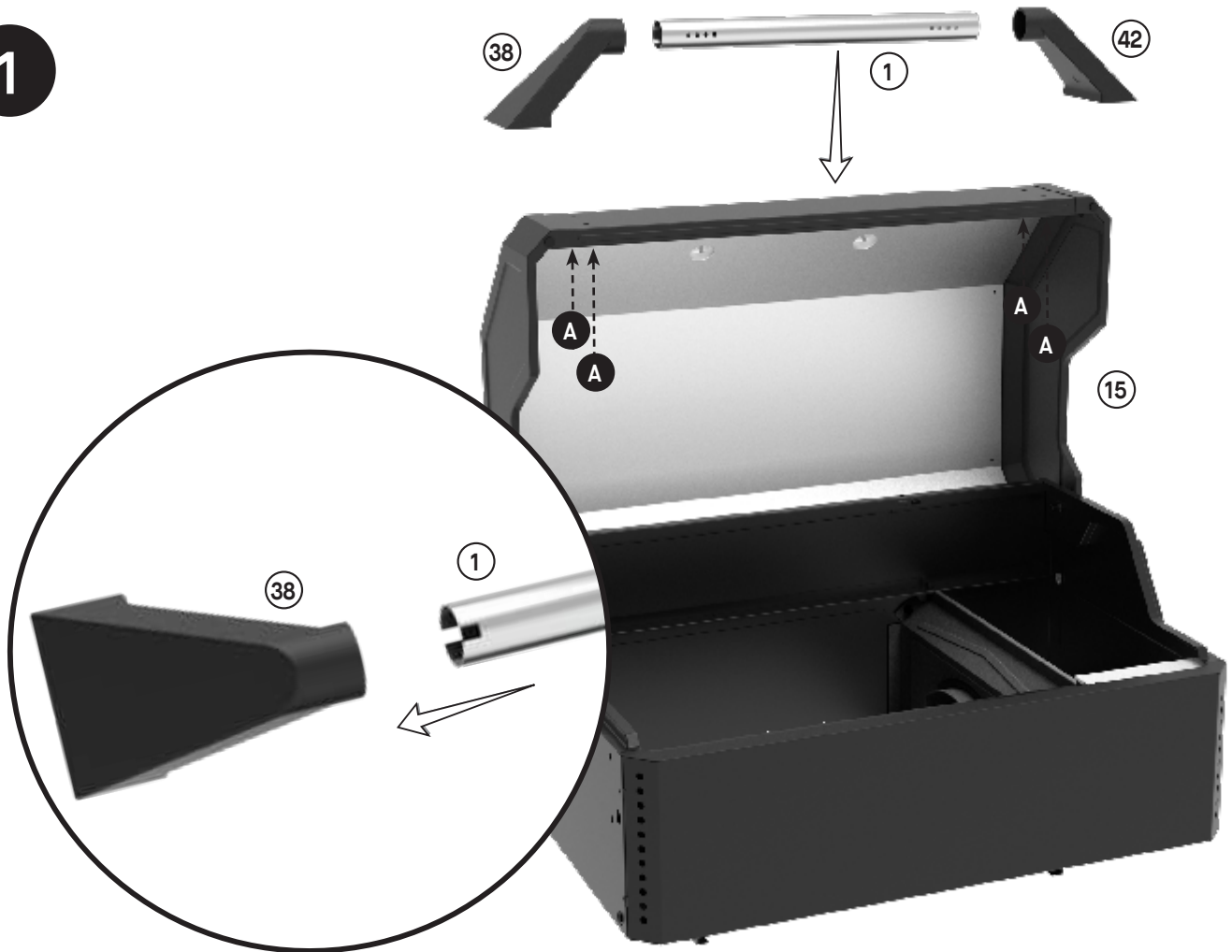

2



3

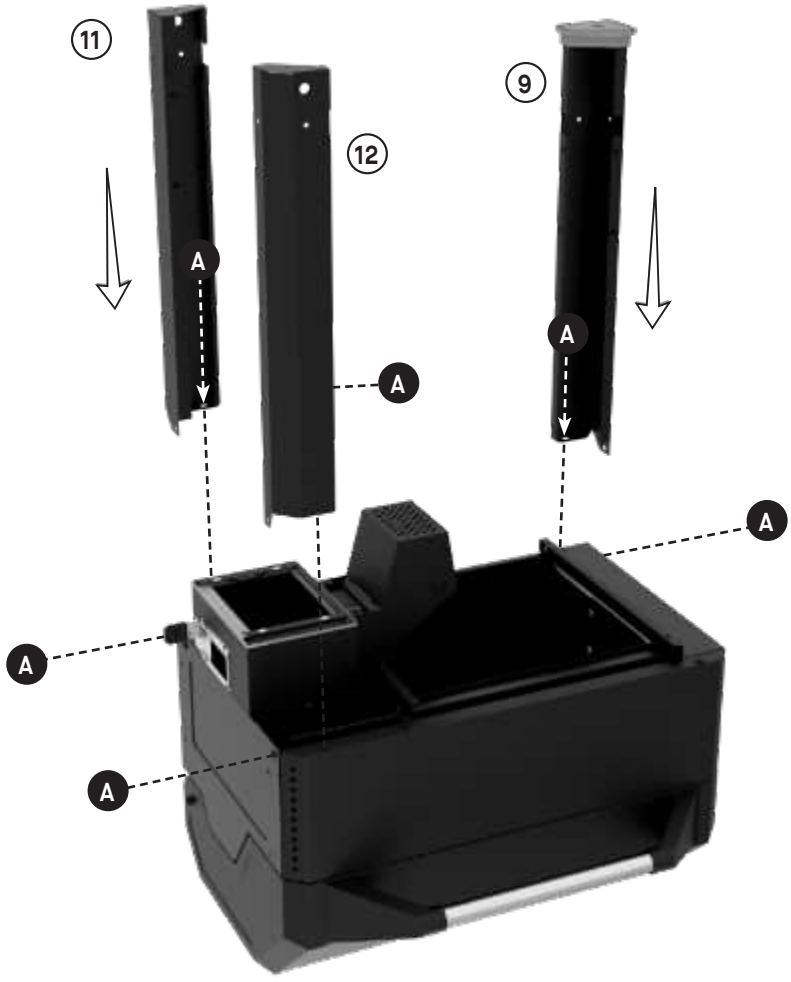

4

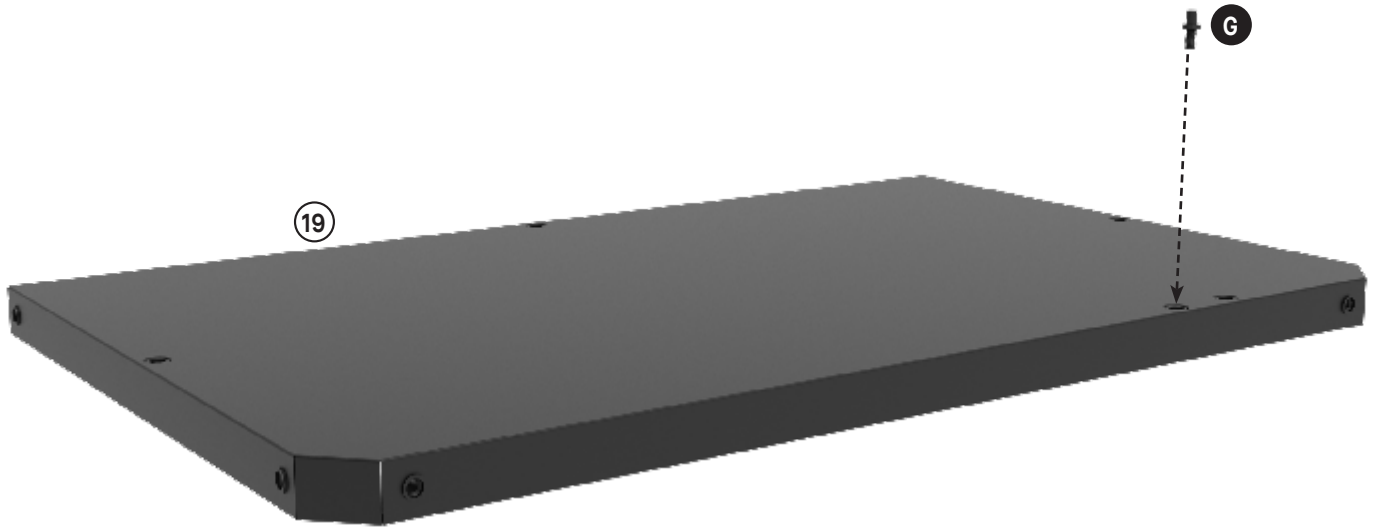

5

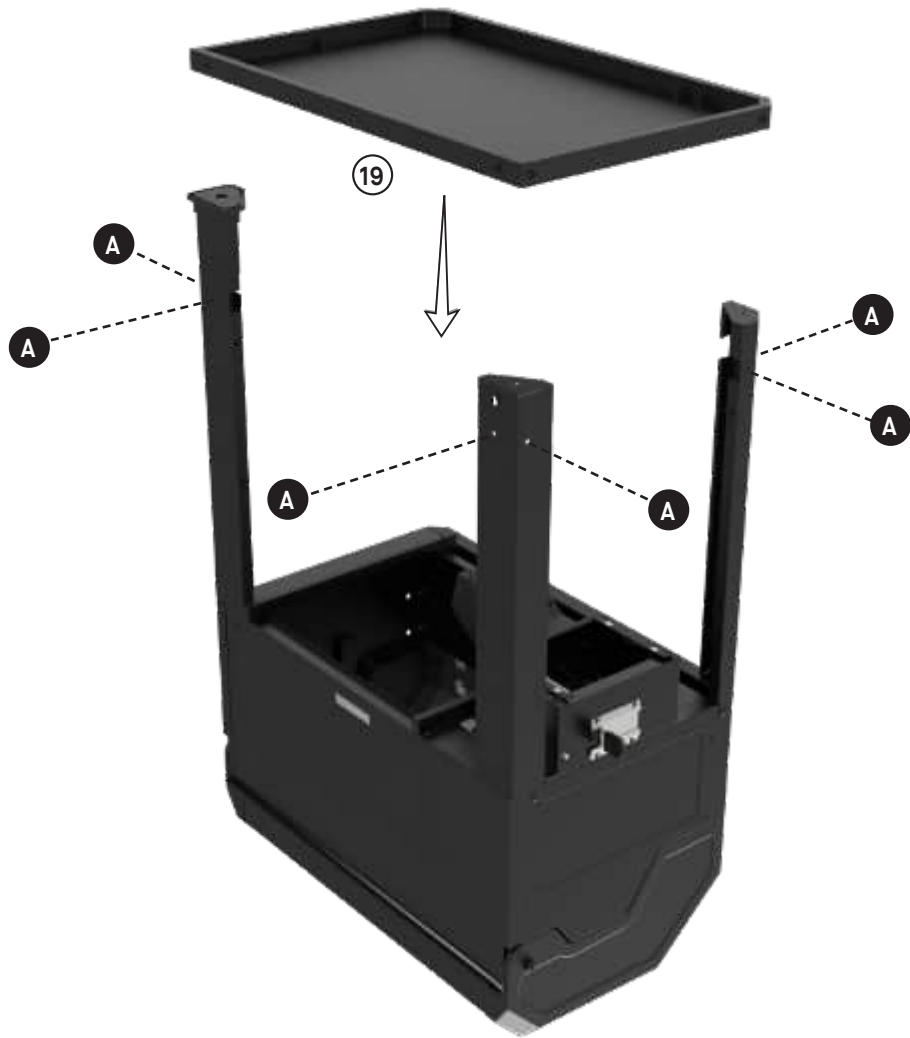

6

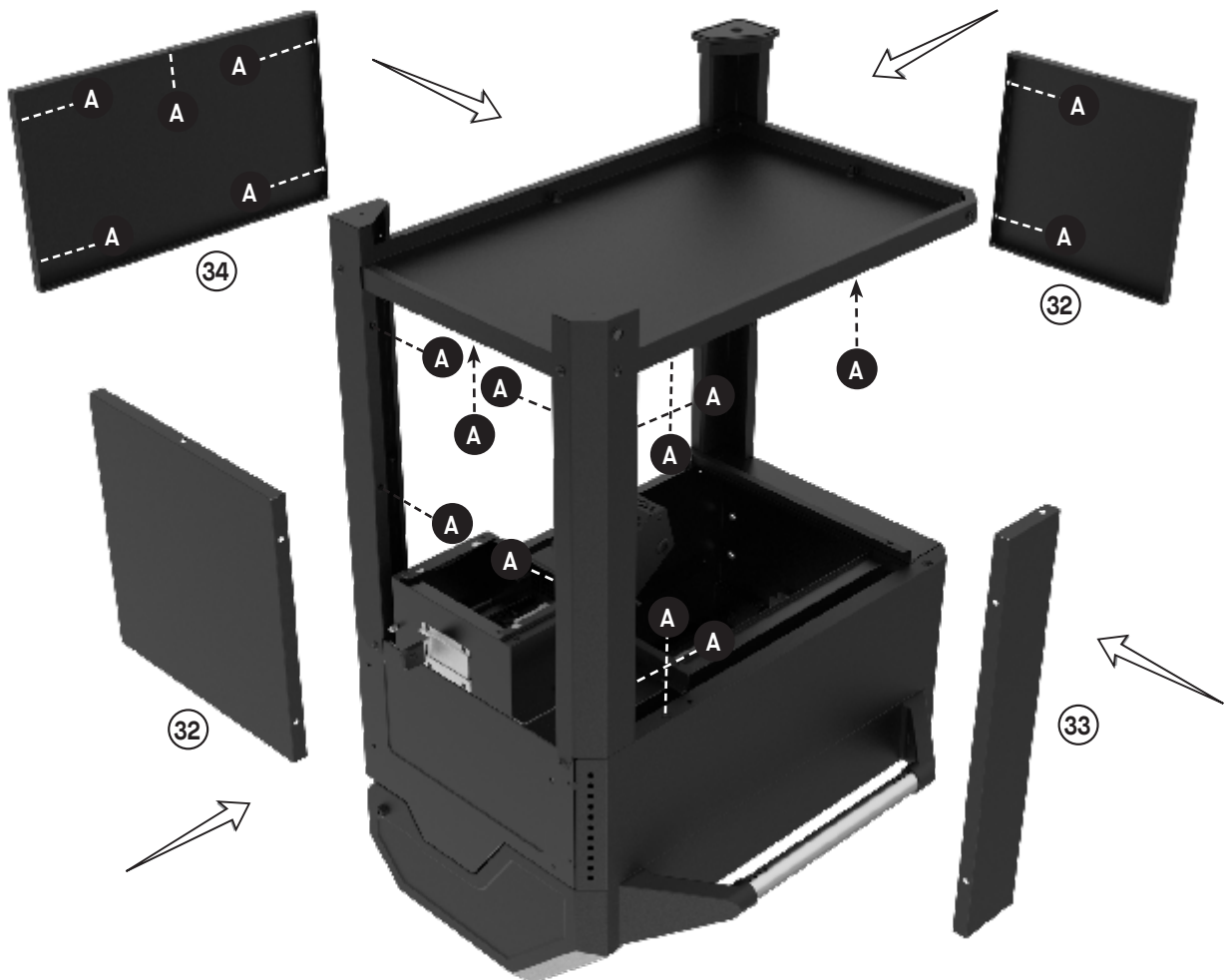



7

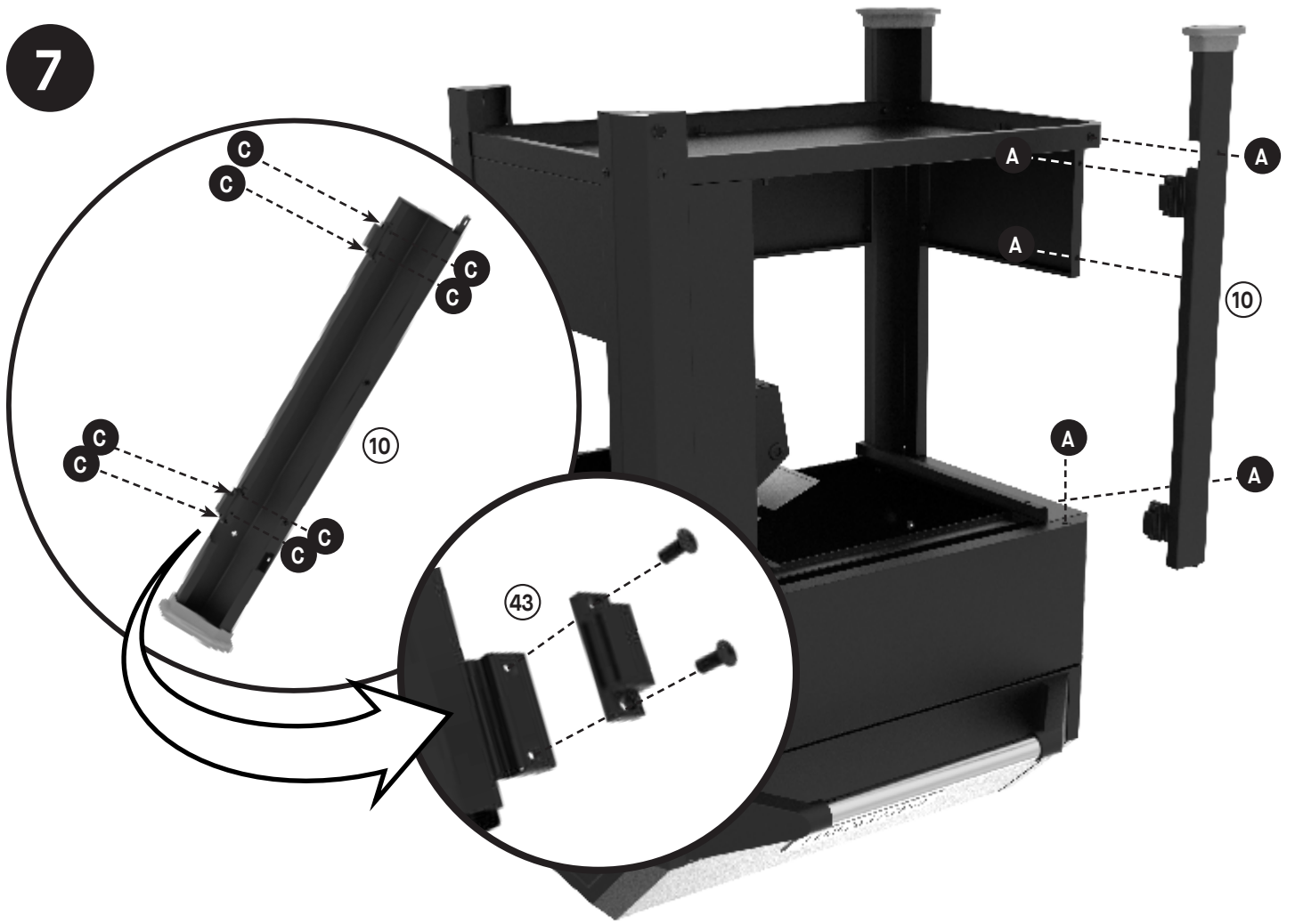

8

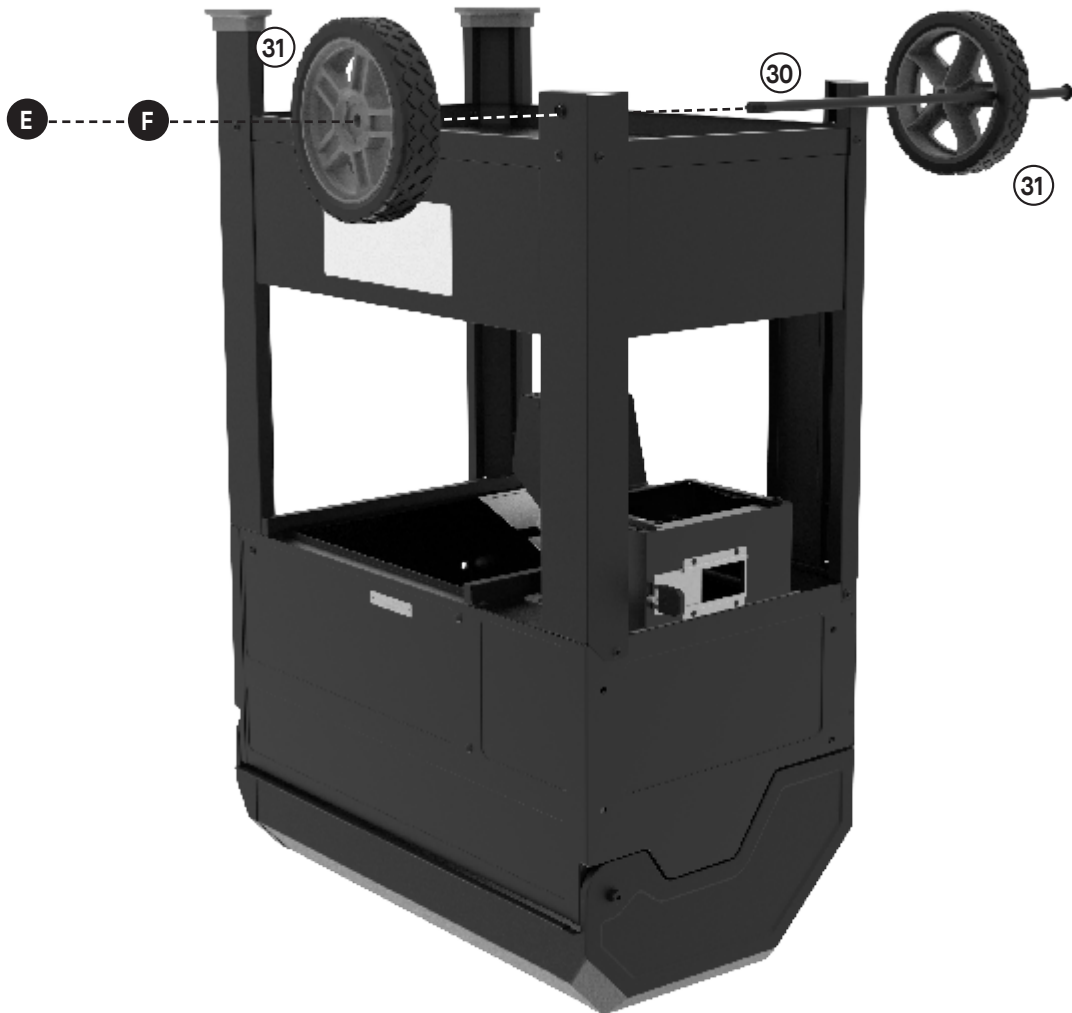

9

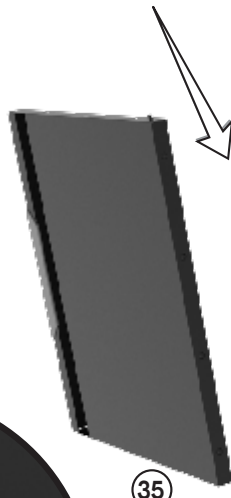
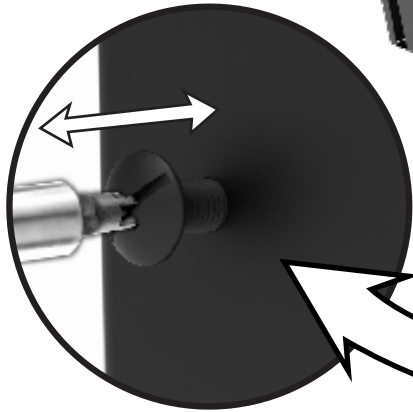
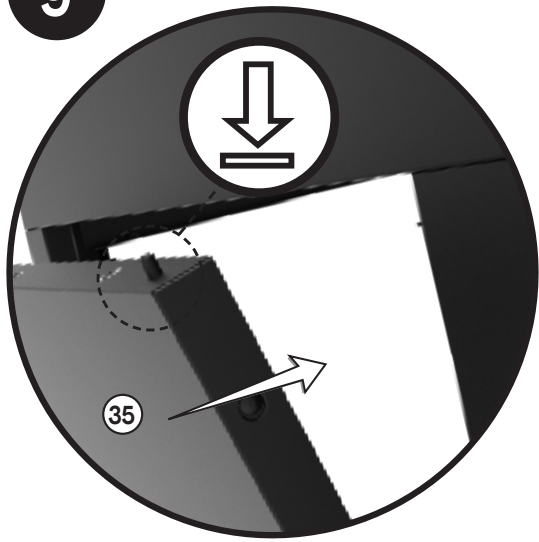

10

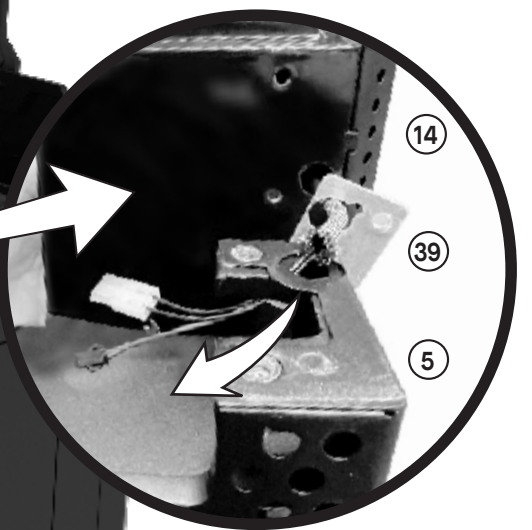
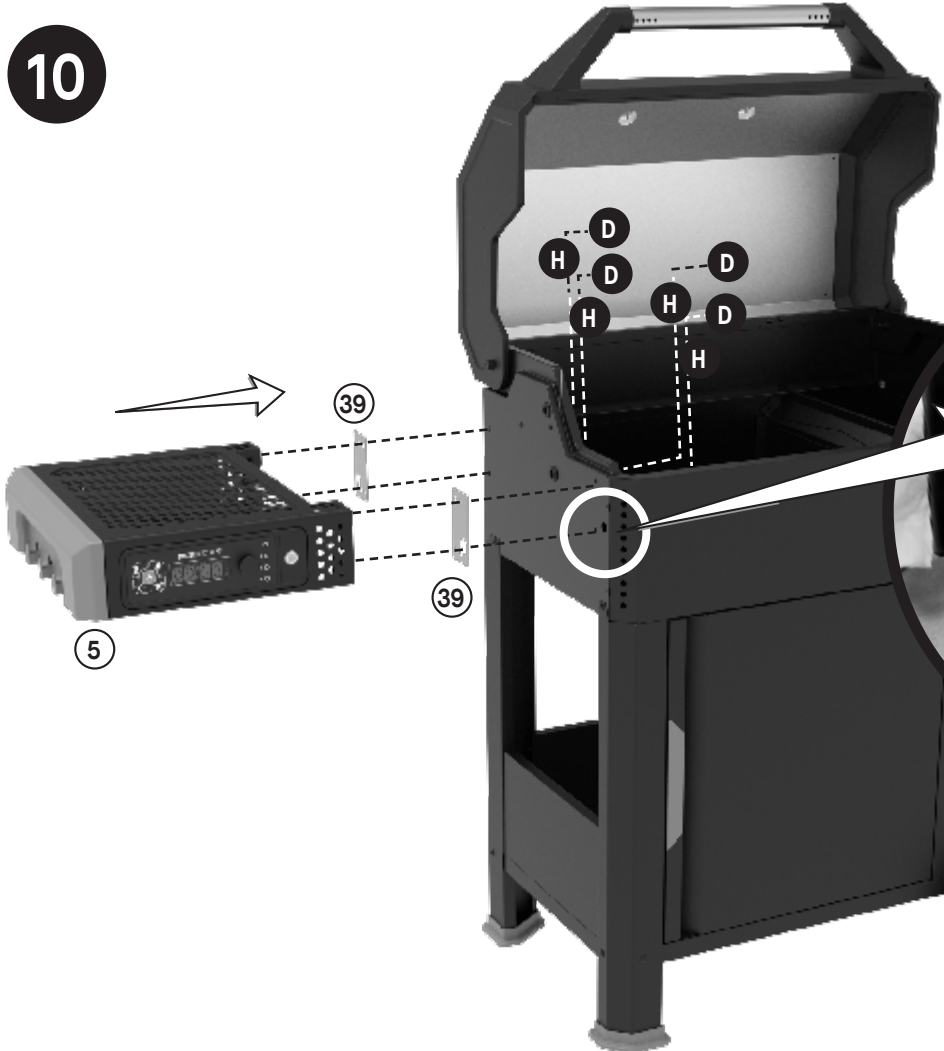

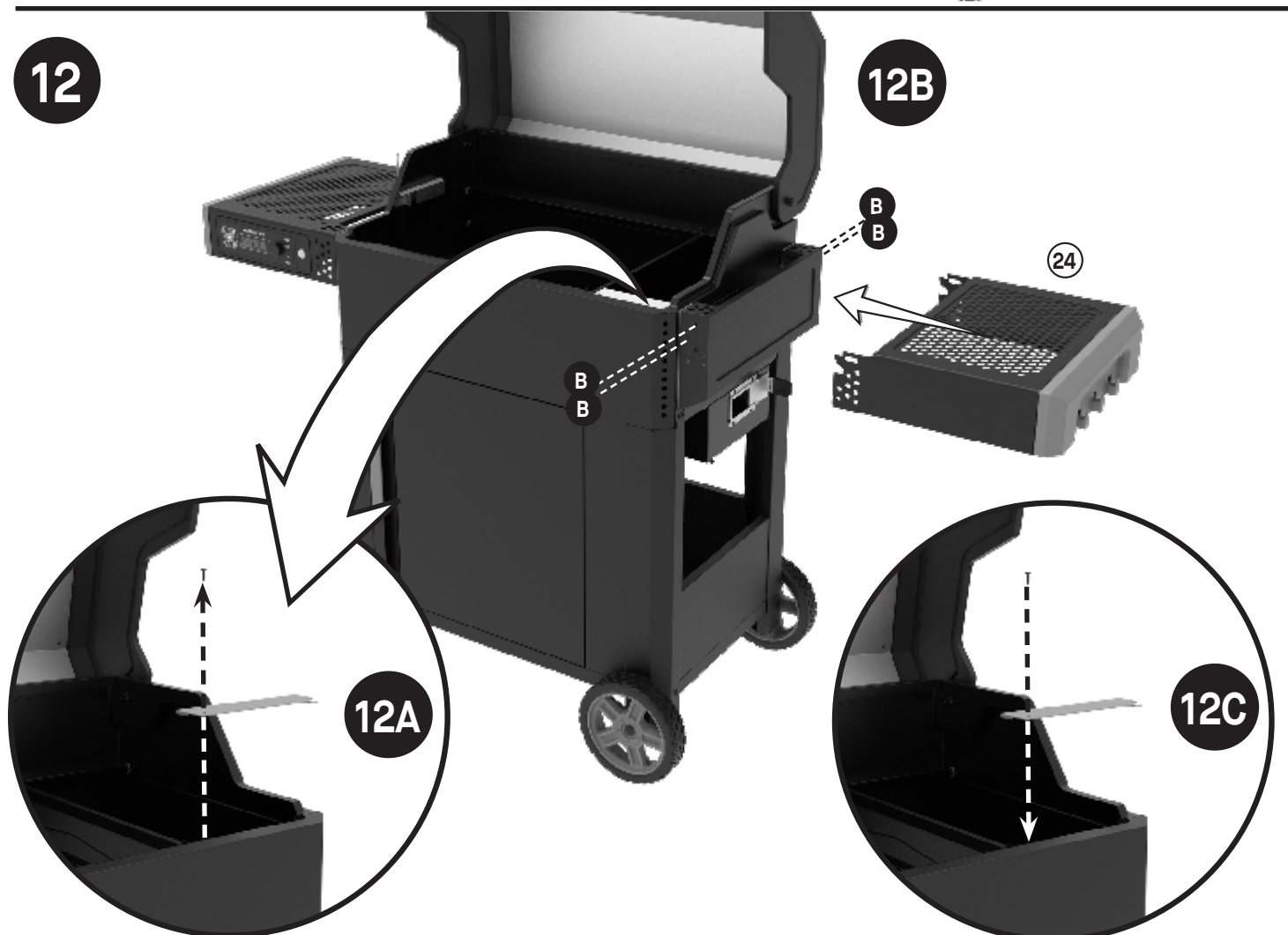
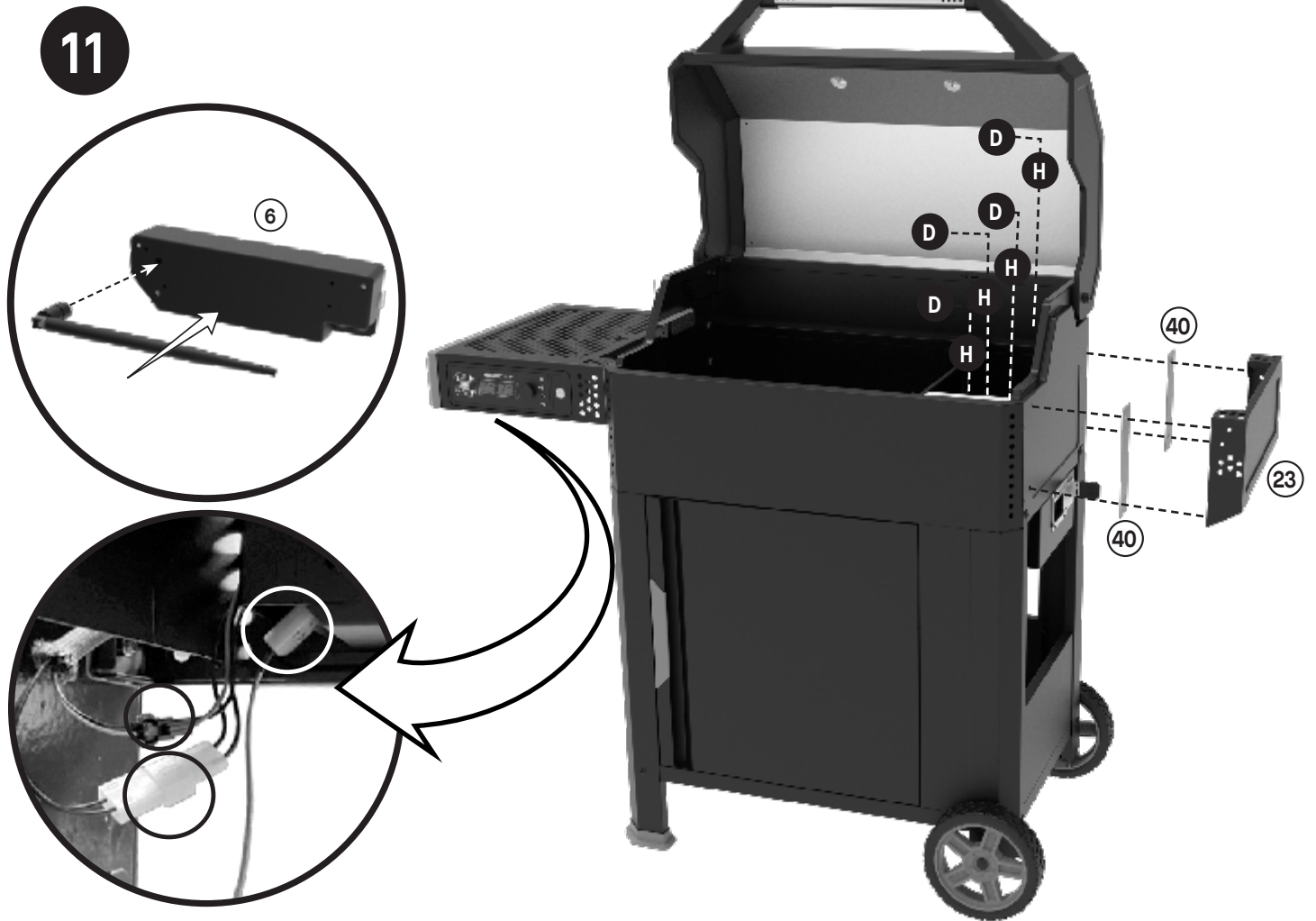

13

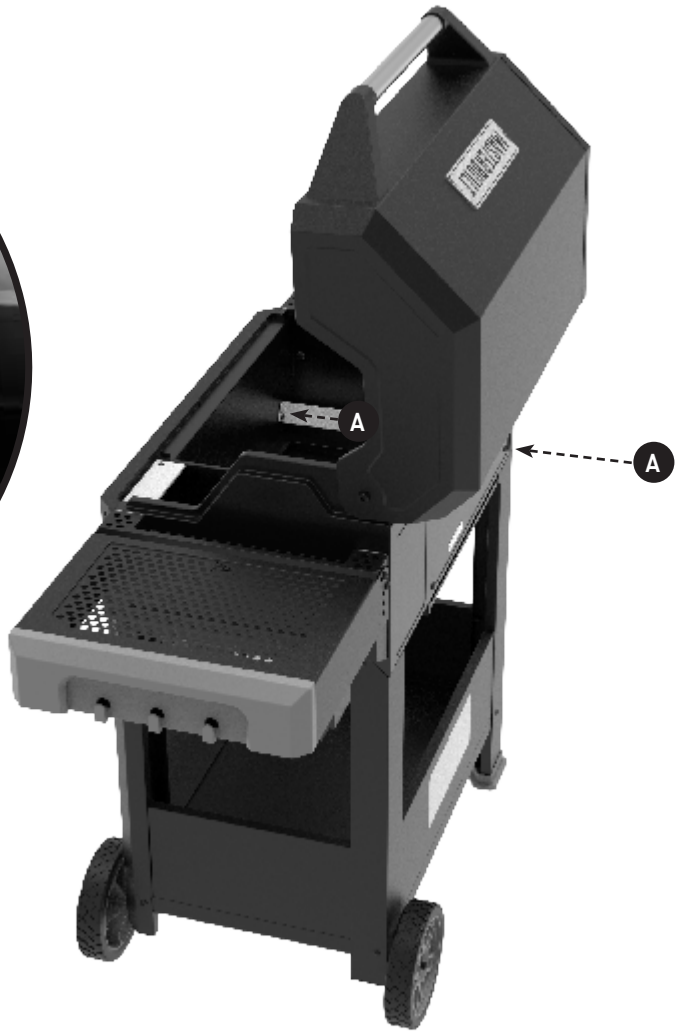
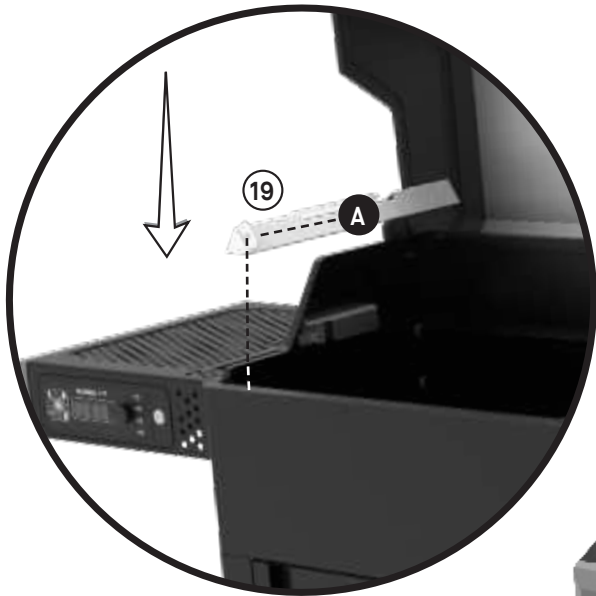

14



15

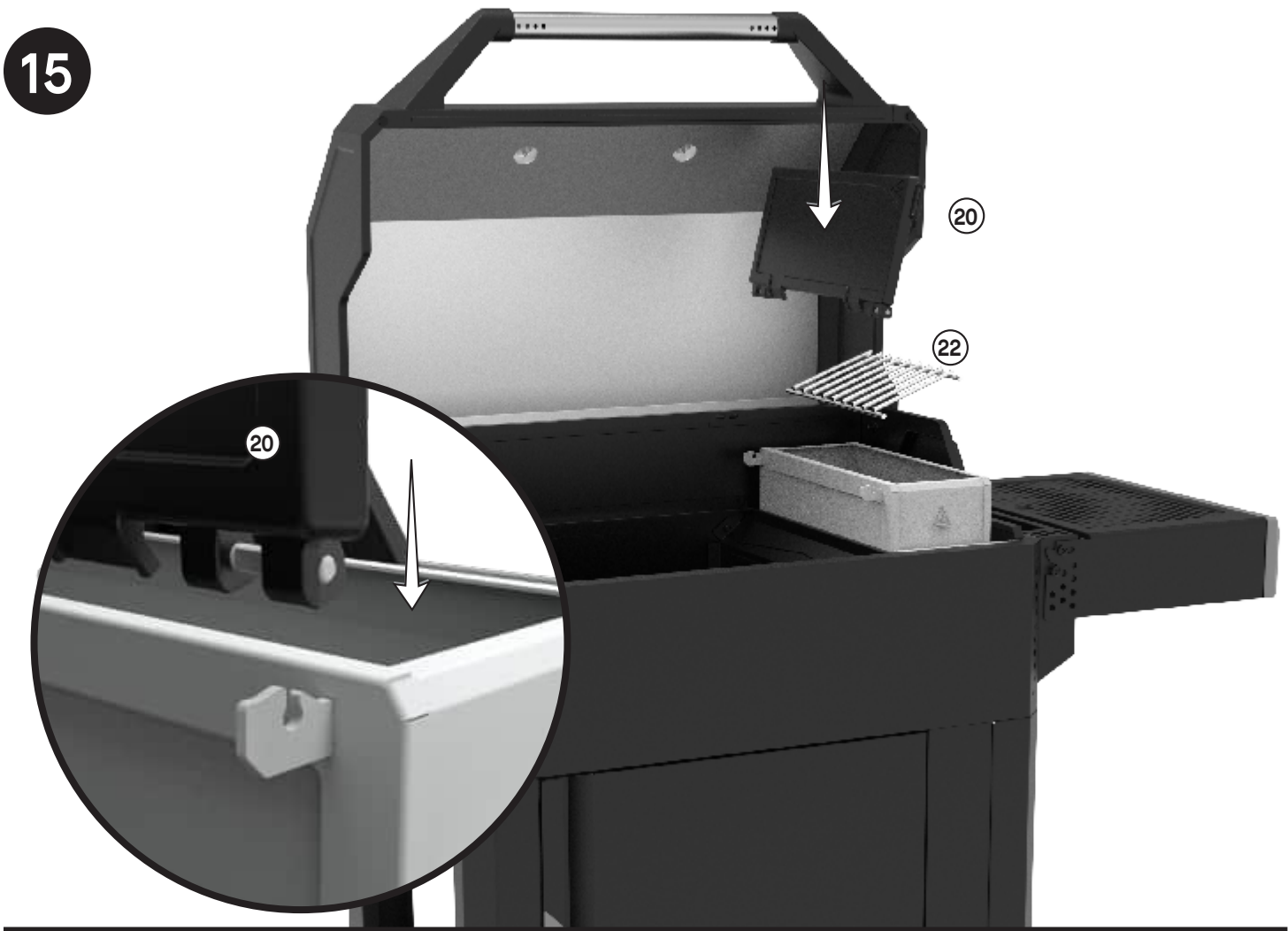

16

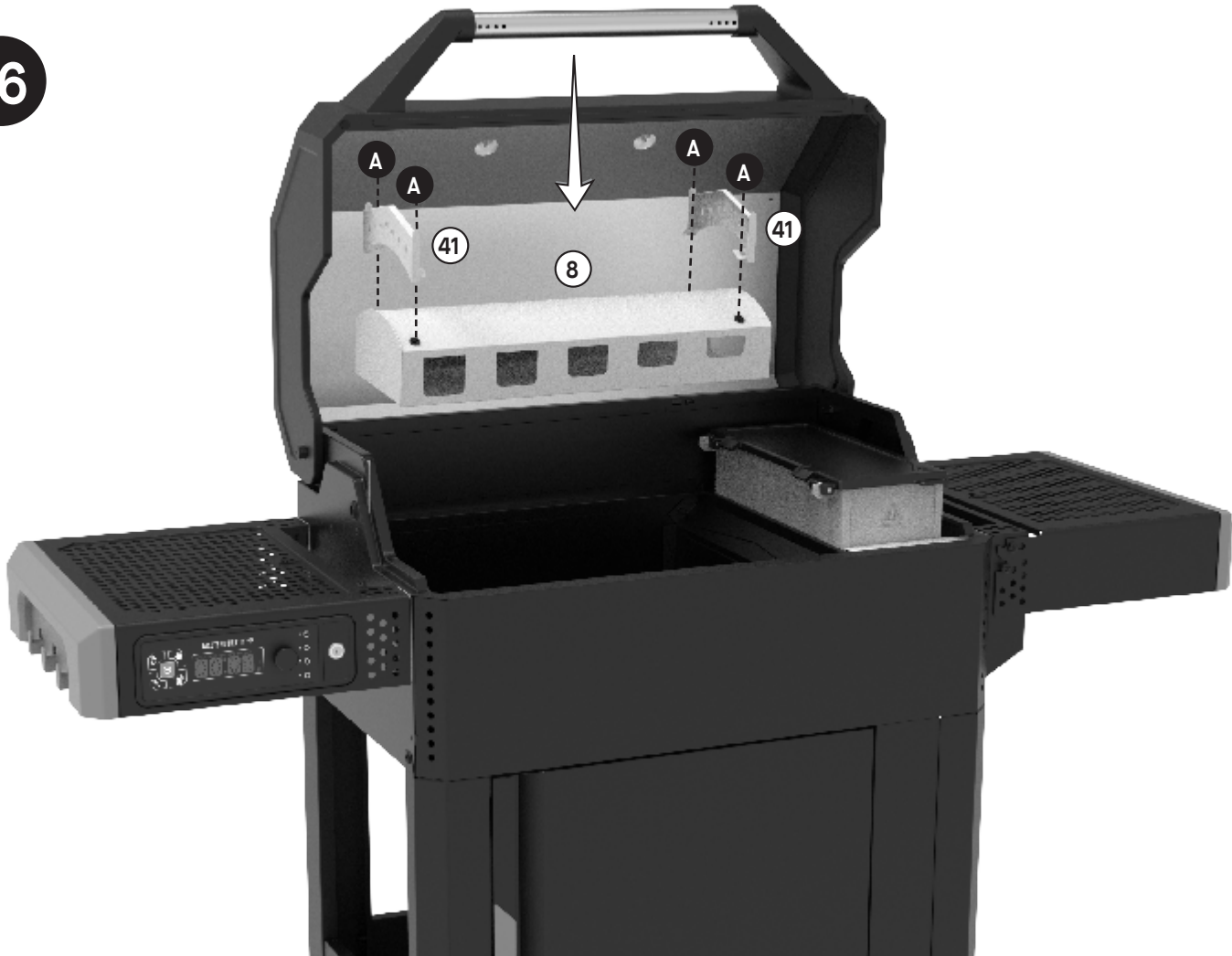

17



18



19

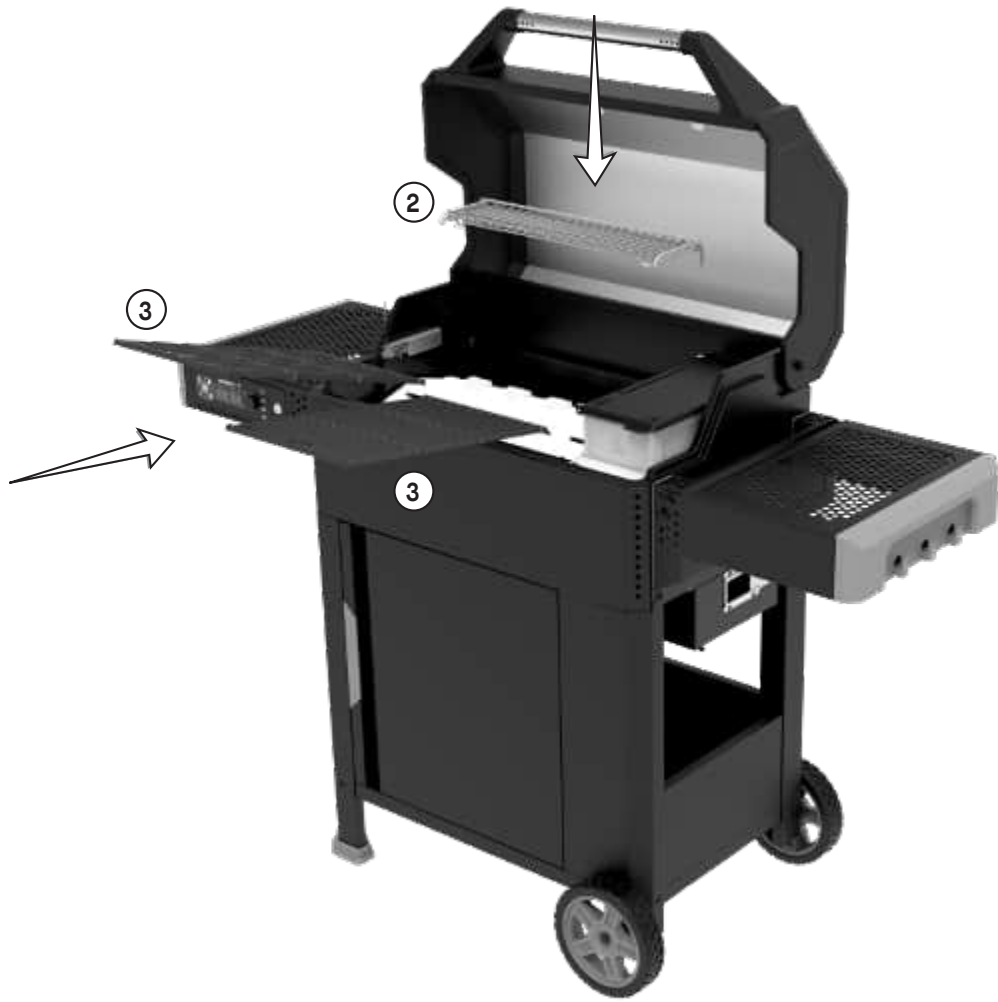

20



21



22





# FOR OUTDOOR USE ONLY. NOT FOR COMMERCIAL USE.



## WARNING

- This manual contains important information necessary for the proper assembly and safe use of the appliance.
- Read and follow all warnings and instructions before assembling and using the appliance.
- Keep this manual for future reference.



## WARNING

- ⚠ WARNING:** This product can expose you to chemicals including DINP, which is known to the State of California to cause cancer, and carbon monoxide, which is known to the State of California to cause birth defects and other reproductive harm. For more information go to [www.P65Warnings.ca.gov](http://www.P65Warnings.ca.gov)



## CARBON MONOXIDE HAZARD

**Failure to follow these instructions could result in fire, explosion or burn hazard which could cause property damage, personal injury, or death.**

- Burning wood chips, wood chunks, wood pellets, charcoal and propane gives off carbon monoxide, which has no odor and can cause death.
- DO NOT burn wood chips, wood chunks, wood pellets, charcoal or propane inside homes, vehicles, tents, garages or any enclosed areas.
- Do not use the barbecue in a confined and/or habitable space e.g. houses, tents, caravans, motor homes, boats. Danger of carbon monoxide poisoning fatality.
- USE ONLY OUTDOORS where it is well ventilated.
- **FOLLOW THESE GUIDELINES TO PREVENT THIS COLORLESS, ODORLESS GAS FROM POISONING YOU, YOUR FAMILY OR OTHERS.**
  - Know the symptoms of carbon monoxide poisoning: headache, dizziness, weakness, nausea, vomiting, sleepiness, and confusion. Carbon monoxide reduces the blood's ability to carry oxygen. Low blood oxygen levels can result in loss of consciousness and death.
  - See a doctor if you or others develop cold or flu-like symptoms while cooking or in the vicinity of this appliance. Carbon monoxide poisoning, which can easily be mistaken for a cold or flu, is often detected too late.
  - Alcohol consumption and drug use increase the effects of carbon monoxide poisoning.
  - *Carbon monoxide is especially toxic to mother and child during pregnancy, infants, the elderly, smokers, and people with blood or circulatory system problems, such as anemia, or heart disease.*



## WARNINGS AND IMPORTANT SAFEGUARDS



### READ ALL INSTRUCTIONS

- Do not leave grill unattended.
- Grill is for OUTDOOR HOUSEHOLD USE ONLY.
- Do not use indoors!
- Use charcoal for fuel only.
- Always use grill in accordance with all applicable local, state, and federal fire codes.
- Potential damage to grill or harm to user may result from failure to follow warnings.
- Never use inside enclosed areas such as patios, garages, buildings or tents.
- Never use inside recreational vehicles or on boats.
- Never operate grill under overhead construction such as roof coverings, carports, awnings, or overhangs. (SEE STRUCTURAL PROXIMITY REQUIREMENTS)
- Keep appliance clear and free from combustible materials such as gasoline and other flammable vapors and liquids.
- Use grill on a level, non-combustible, stable surface such as dirt, concrete, brick or rock. An asphalt surface (blacktop) may not be acceptable for this purpose.
- Do not use grill on wooden or flammable surfaces.
- Grill MUST be on the ground. Do not place grill on tables or counters. DO NOT move grill across uneven surfaces.
- Grill should only be rolled on smooth surface.
- Grill should never be rolled up/down stairs or uneven surface.
- Never use grill as a heater (READ CARBON MONOXIDE HAZARD).
- Never use appliance for anything other than its intended use. This grill is NOT for commercial use.
- Keep a fire extinguisher accessible at all times while operating the grill.
- When cooking with oil or grease, have a type BC or ABC fire extinguisher readily available.
- In the event of an oil or grease fire do not attempt to extinguish with water. Immediately call the fire department. A type BC or ABC fire extinguisher may, in some circumstances, contain the fire.



## WARNINGS AND IMPORTANT SAFEGUARDS



- Before each use check all nuts, screws and bolts to make sure they are tight and secure.
- Use of alcohol, prescription, or non-prescription drugs may impair user's ability to properly assemble or safely operate grill.
- Keep children and pets away from grill at all times. Do NOT allow children to use grill. Close supervision is necessary when children or pets are in the area where grill is being used.
- The appliance is not to be used by persons (including children) with reduced physical, sensory or mental capabilities, or lack of experience and knowledge, unless they have been given supervision or instruction.
- The appliance is not to be used by children aged from 8 years and above and persons with reduced physical, sensory or mental capabilities, or lack of experience and knowledge, unless they have been given supervision or instruction.
- Do NOT allow anyone to conduct activities around grill during or following its use until it has cooled.
- DO NOT bump or impact the grill to prevent personal harm, damage to grill, or spillage/splashing of hot cooking liquid.
- Extreme caution must be used when moving an appliance containing hot oil or other hot liquids.
- Never move grill when in use. Allow grill to cool completely (below 115°F (45°C)) before moving or storing.
- The grill is HOT while in use and will remain HOT for a period of time afterwards and during cooling process. Use CAUTION. Wear protective gloves/mitts.
- Do not touch HOT surfaces. Use handles or knobs.
- Never use glass, plastic or ceramic cookware in smoker. Never place empty cookware in grill while in use.
- Accessory attachments not supplied by Masterbuilt<sup>(R)</sup> are NOT recommended and may cause injury.
- Do not store grill with hot ashes or charcoal inside grill/hopper. Store only when fire is completely out and all surfaces are cold.
- The grill, hopper and hopper lid are HOT while in use and will remain HOT for a period of time afterwards and during cooling process. Use CAUTION. Wear protective gloves/mitts.
- Be careful when removing food from grill. All surfaces are HOT and may cause burns. Use protective gloves/mitts or long, sturdy, cooking tools for protection from hot surfaces or splatter from cooking liquids.
- Grill is hot during use. To avoid burns, keep face and body away from door(s) and vents. Steam and hot air are expelled during use.
- Hopper, hopper lid, ash door are HOT while the grill is in use and during cooling. Wear protective gloves when working with and around these components.
- Grill has an open flame. Keep hands, hair, and face away from flame. Do NOT lean over grill when lighting. Loose hair and clothing may catch fire.
- DO NOT obstruct flow of combustion and ventilation.
- Do not cover cooking grates with metal foil. This will trap heat and may cause damage to the grill.
- Never leave HOT coals or ashes unattended.
- Do not remove ashes while ashes and charcoal are HOT.
- Keep hands, hair, and face away from the burning charcoal. Be careful of loose hair and clothing during operation as they could catch fire.
- Use protective gloves when handling this grill or working with fire. Use protective gloves or long, sturdy fireplace tools when adding wood or charcoal.
- Never use charcoal lighting fluid, gasoline, alcohol or other highly volatile fluids to ignite charcoal. These fluids can explode causing injury or death. Always follow specific lighting instructions for this grill.
- Never overfill charcoal hopper. This can cause serious injury as well as damage to the grill.
- Dispose of cold ashes by placing them in aluminum foil, soaking with water, and discarding in a non-combustible container.
- CAUTION - To reduce the risk of electric shock, keep extension cord connection dry and off the ground.
- CAUTION - To reduce the risk of electric shock, do not immerse cord, plug or control panel in water or other liquid.
- WARNING: Risk of Electric Shock. Install only to a covered Class A GFCI receptacle that has an enclosure that is weatherproof with the attachment plug cap inserted or removed.
- WARNING: Not for use with receptacles that are weatherproof only when the receptacle is covered (attachment plug cap not inserted and receptacle cover closed).
- When using electrical appliances, basic safety precautions should always be followed including the following:
  1. Do not plug in the appliance until fully assembled and ready for use.
  2. Use only approved grounded electrical outlet.
  3. Do not use during an electrical storm.
  4. Do not expose appliance to rain or water at any time.
- Do not operate any appliance with a damaged cord or plug, or after appliance malfunctions or has been damaged in any manner. If the supply cord is damaged, it must be replaced by the manufacturer, its service agent or similarly qualified persons in order to avoid hazard.
- Extension cords may be used if care is exercised in their use.
- Outdoor extension cords must be used that are marked with suffix "W" and with the statement "Suitable for Use with Outdoor Appliances."
- The extension cord must be a grounding-type 3-wire cord.
- If an extension cord is used, be sure that:
  1. The marked electrical rating of the extension cord should be at least as great as the electrical rating of the appliance; and
  2. The cord should be arranged so that it will not drape over the counter top or tabletop where it can be pulled by children or tripped over unintentionally.



## WARNINGS AND IMPORTANT SAFEGUARDS



- Do not let cord hang on or touch hot surfaces.
- Do not place cord on or near a gas or electric burner or in a heated oven.
- To disconnect, turn controller "OFF" then remove plug from outlet.
- Unplug from outlet when not in use and before cleaning. Allow appliance to cool completely before adding/removing internal components.
- Do not clean this product with a water sprayer or the like.
- Never open hopper after initial startup or during use. If it is necessary to refill charcoal during use follow the specific reload instructions for this grill and always wear protective gloves.
- Never operate the grill with the temperature probe removed. This can cause the grill to overheat and cause serious personal injury and/or damage to the grill.
- This device complies with Industry Canada licence-exempt RSS standard(s). Operation is subject to the following two conditions:
  1. This device may not cause interference, and
  2. This device must accept any interference, including interference that may cause undesired operation of the device.
- This equipment complies with IC radiation exposure limits set forth for an uncontrolled environment. This equipment should be installed and operated with minimum distance 20 cm between the radiator & your body.
- **WARNING!** Do NOT store combustible materials under the grill or in the grill cabinet. Hot ash can reach the grill cabinet. Use caution.



## ELECTRIC REQUIREMENTS



- 100-120VAC, 60HZ, 1.1A, 82W



## STRUCTURAL PROXIMITY REQUIREMENTS



Maintain a minimum distance of 10 ft (3 m) from rear, sides and top of grill to all overhead construction, walls, rails or other combustible construction materials.

Maintain a minimum distance of 10 ft (3 m) from all combustible and flammable materials such as, wood, plants, grass, brush, paper, gasoline, or canvas.

This clearance provides adequate space for proper combustion, air circulation and venting. Grill should not be used on combustible materials like wood decks or other combustible materials.

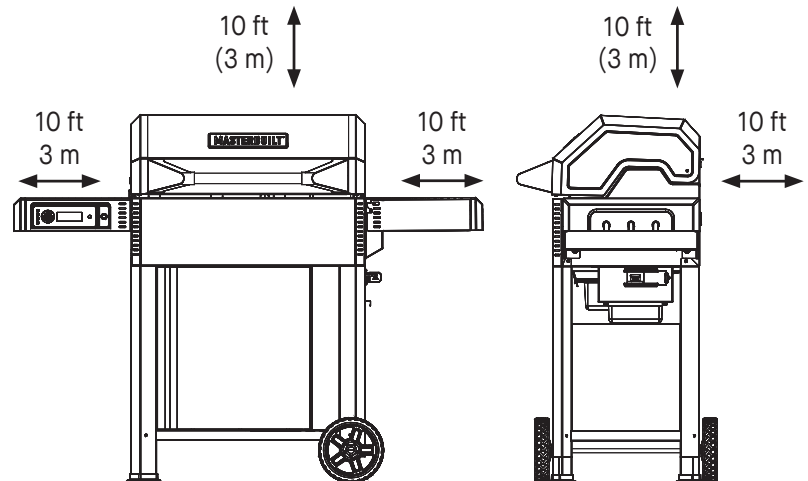

## WARNING



Electric power cord is a trip hazard.

## SAVE THESE INSTRUCTIONS

This product does not come with charcoal or wood chunks.

# Operating Instructions

## PRE-SEASONING

**Pre-seasoning will rid your grill of chemicals and oils left over by the manufacturing process.**

**PRE-SEASON GRILL PRIOR TO FIRST USE.**

1. Fill the hopper with charcoal approximately 1/4–1/2 full.
2. Start grill following the START-UP instructions and set the temperature to 250°F (121°C) for 60 minutes.
3. After 60 minutes set the temperature to 400°F (204°C) for 30 minutes.
4. Shut down the grill following the SHUTDOWN instructions.
5. Allow grill to cool COMPLETELY.
6. Using a napkin or cloth, rub a light coat of cooking oil on grates, sear plate, warming racks, and the inside of the grill lid and body. Use caution, the grill will be HOT to the touch.
7. Repeat steps 3–6 at 350°F (175°C).

Frequent seasoning prevents rusting. If rusting occurs, clean with a steel brush, apply vegetable shortening and heat as indicated above.

## REGULAR START-UP

1. Plug the grill in and power ON the controller.
2. DO NOT LOAD CHARCOAL UNTIL STEP 5.
3. Press the auto ignite button to preheat the ignitor:
  - a. Ignite button should now be flashing.
  - b. Controller display should be flashing 450F (232C).
4. Scroll controller knob to change desired temperature.
  - a. Temperature Selection Options:
    - Press the set temp button to select the temperature shown on the display.
    - If you do not scroll the knob, the controller will auto select the temp on display (default temp 450F / 232C).
5. Fill the MiniHopper with charcoal (no more than 7lbs/3kgs of briquette or 5lbs/2.25kgs of lump).
6. Close the hopper lid and grill lid.
7. Wait for the auto ignite button to stop flashing (this should take approximately 45 seconds).
8. Place 1 fire starter in the fire starter holder (see fig. 1)
9. Slide the fire starter tray into the lower hopper until it stops and close the door.
10. The grill will need to run a startup sequence; it may take a few moments for the fan to turn on.

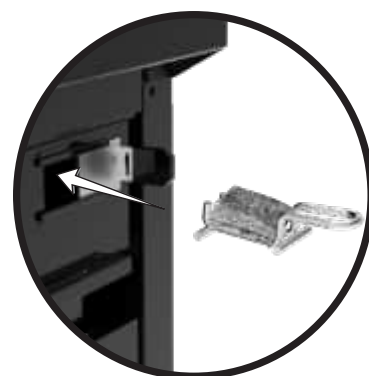

**Figure 1**

### IGNITOR TIPS:

- a. Flashing ignitor button = ignitor preheating (DO NOT load fire starter while the ignitor is preheating).
- b. Solid ignitor button = igniter is ON/hot.
- c. Ignitor will not turn ON if grill is above 200F (93C).
- d. IF temp is already set, ignitor will not prompt you to set temp.
- e. Any time the ignitor is activated, the grill will run the startup sequence. During this sequence the fan will not run by PID. Fan will return to PID after the startup sequence completes. The startup sequence is approximately 8 minutes.

**NOTE:** For proper fire starter ignition, it is important to follow the steps listed above in the proper sequence. Failure to follow the steps may result in a failed startup procedure.

In some cases, the fire-starter will fail to ignite during the startup sequence. This can be due to the nature of the fire-starter itself. If the fire-starter does not ignite, power off the grill, remove the failed fire-starter, power ON the grill and reset your temperature, then, after the ignitor pre-heats, reinstall a NEW fire-starter.

# Operating Instructions

## START-UP

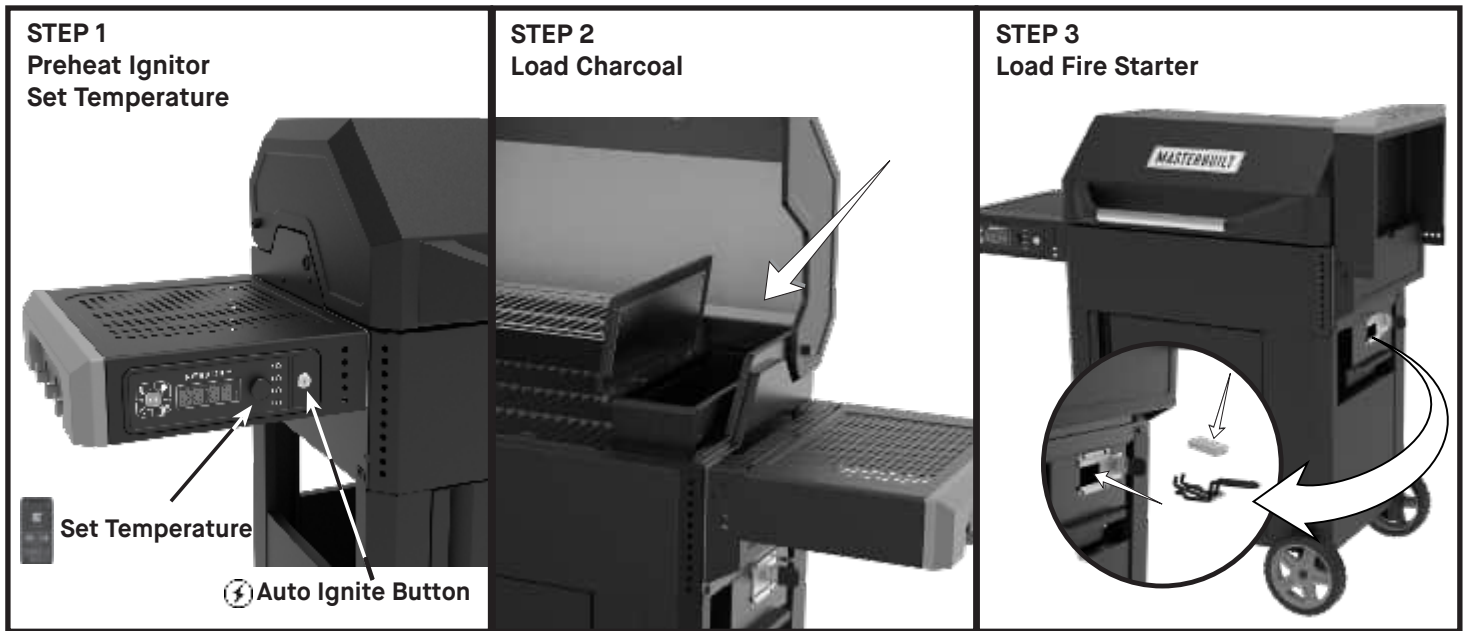

## MANUAL FIRESTARTER IGNITION

If fire starter fails to ignite with the ignitor button, you can manually ignite the hopper with the steps below.

1. Plug the grill in and power ON the controller.
2. Fill the MiniHopper with charcoal (no more than 7lbs/3kgs of briquette or 5lbs/2.25kgs of lump).
3. Keep hopper lid OPEN.
4. Place 1 fire starter in the fire starter holder (see fig. 1)
5. Slide the fire starter tray into the lower hopper until it stops.
6. Manually ignite the fire starter.
7. Close the fire starter door.
8. Wait 2-3minutes to allow the charcoal to ignite before closing the hopper lid.
9. Once charcoal has started to burn, close the hopper lid.
10. Shut the grill lid and set the temperature on the controller.

## RELOAD

If it is necessary to refill the hopper while cooking, follow the safe reloading instructions below.

1. Ensure the fan is PAUSED before you begin to reload.
2. Press the power button to enable the PAUSE function (the controller will display HOLD)
3. Add charcoal to hopper (no more than 7lbs/3kgs of briquette or 5lbs/2.25kgs of lump). Use EXTREME caution, hopper lid will be HOT. Wear protective gloves and use tongs to open the hopper lid
4. Close hopper lid and un-pause the controller by pressing the power button.

# Operating Instructions

## SHUTDOWN

1. After cooking is complete, turn controller off and unplug.
  2. Close hopper lid and grill lid.
  3. Allow grill to cool to the touch before storing.
  4. Once grill is cool to the touch, empty the ash cup, cover, and store your grill in a dry location.
- \* NOTE: Charcoal will not be saved after shutting the grill down. To promote a faster shutdown procedure, limit the amount of charcoal to fit your cook time.

## ADDING SMOKE/FLAVOR

Mix wood chunks in the hopper with charcoal. Power on and set the temperature.

\* NOTE: Never use more than 1/2 lbs of wood chunks throughout the hopper.

## GRATE LIFTER

Use your grate lifter to handle your cooking grates.

CAUTION! Cooking grates can be HOT! Use the grill gripper to re-position the cooking grates throughout your cook. \* NOTE: The grates should be as close together as possible.

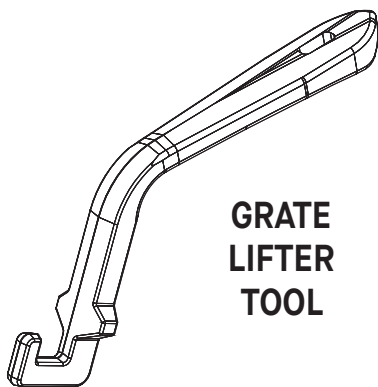

**GRATE  
LIFTER  
TOOL**

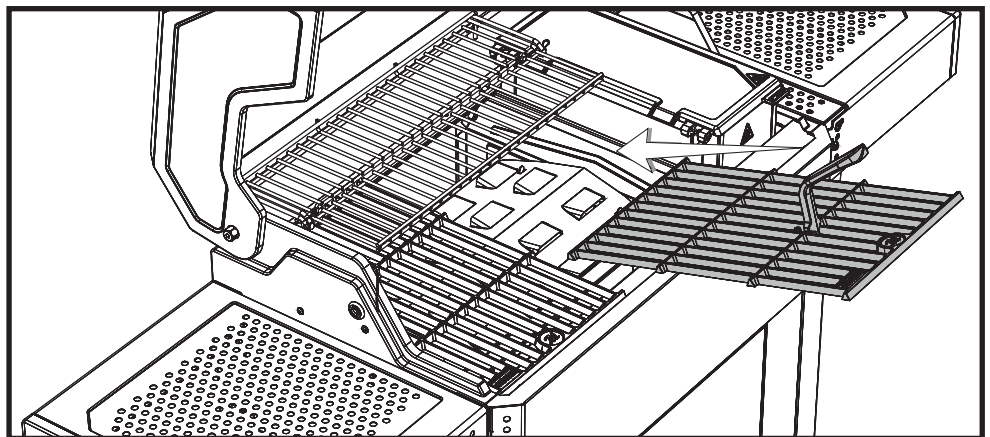

## CORD STORAGE

The cord is designed to wrap on the storage bracket behind the side shelf. Before storing, turn controller "OFF" and remove plug from outlet.

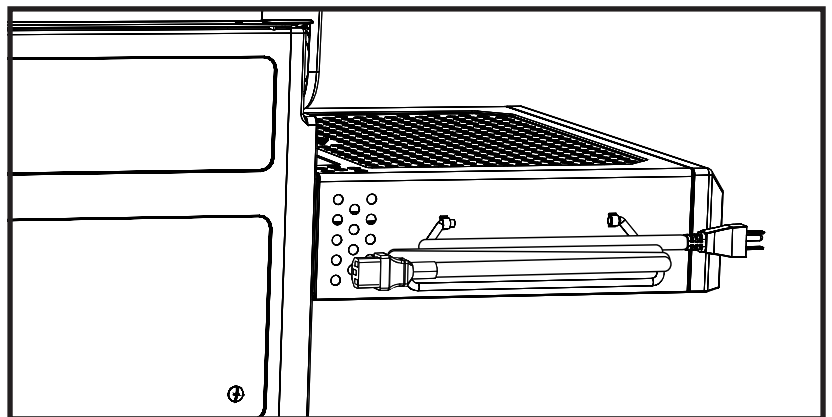

# Operating Instructions

## CONTROL PANEL



### Power ON/Off Controller:

1. Press button to power controller ON.
2. Single press while on = Pause function
3. Long press while on = Power OFF



### Ignite Button:

1. Press button to auto ignite the fire starter.



### Set Temperature:

1. Press button.
2. Turn knob to desired temperature.
3. Press button again to set temperature (Temperature will automatically set after 3 seconds.)



### Set Time:

#### • Countdown Timer

1. Press button.
2. Turn knob to desired hours.
3. Press button to set hours.
4. Turn knob to desired minutes.
5. Press button to set minutes. The timer will start.
6. Press button to pause and resume timer.
7. Press and hold button to reset timer.

#### • Count Up Timer

1. Press and hold button.
2. Timer will begin counting up from 00:00. Timer will count by Minutes:Seconds and then Hours:Minutes.
3. Press button to pause and resume timer.
4. Press and hold button to reset timer.



### Set Meat Probe Temperatures:

1. Press button and turn knob to select meat probe (MP1, MP2, MP3, MP4).
2. Press temperature button.
3. Turn knob to desired temperature.
4. Press temperature button again to set the temperature.
5. Once set temperature is reached, alarm will sound. Press any button to clear.



### Viewing Information on Display:

- Turning the knob will advance the display through grill temperature, timer and meat probes; MP1, MP2, MP3 and MP4.

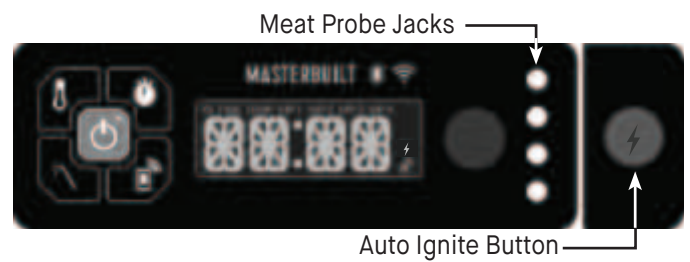

### Set Temperature From F° to C° :

1. With power off, hold set temp button
2. Press power button
3. Unit powers up with "F" or "C" flashing on display
4. Use knob to select temp unit
5. Press set temp to confirm

# Operating Instructions

## BLUETOOTH + WiFi



### Pairing Grill with Smart Device(s):

1. Download the Masterbuilt app from the Apple App Store or Google Play Store onto your smart device(s). For more information go to [masterbuilt.com/pages/app-device-requirements](http://masterbuilt.com/pages/app-device-requirements).
2. Once the download is complete, open the Masterbuilt app and follow the instructions for pairing your Bluetooth + WiFi grill and smart device(s).

## BLUETOOTH



### Pairing Grill with Smart Device(s):

1. Download the Masterbuilt app from the Apple App Store or Google Play Store onto your smart device(s). For more information go to [masterbuilt.com/pages/app-device-requirements](http://masterbuilt.com/pages/app-device-requirements).
2. Once the download is complete, open the Masterbuilt app and follow the instruction for pairing your Bluetooth grill and smart device(s).

This device complies with Part 15 of the FCC Rules. Operation is subject to the following two conditions:

1. This device may not cause harmful interference, and
2. This device must accept any interference received, including interference that may cause undesired operation.

### FCC Warning:

Warning: Changes or modifications to this smoker not expressly approved by the party responsible for compliance could void the user's authority to operate the equipment.

### FCC Statement:

This equipment has been tested and found to comply with the limits for a Class B digital device, pursuant to Part 15 of the FCC Rules. These limits are designed to provide reasonable protection against harmful interference in a residential installation. This equipment generates, uses and can radiate radio frequency energy and if not installed and used in accordance with the instructions, may cause harmful interference to radio communications.

However, there is no guarantee that interference will not occur in a particular installation. If this equipment does cause harmful interference to radio or television reception, which can be determined by turning the equipment off and on, the user is encouraged to try to correct the interference by one or more of the following measures:

1. Reorient or relocate the receiving antenna.
2. Increase the separation between the equipment and receiver.
3. Connect the equipment into an outlet on a circuit different from that to which the receiver is connected.
4. Consult the dealer or an experienced radio/TV technician for help.

Note: If you lose connection, smoker will continue as programmed. Smoker can be operated from the control panel if pairing or connection fails.

This device contains license-exempt transmitter(s)/receiver(s) that comply with Innovation, Science, and Economic Development Canada's license-exempt RSS(s). Operation is subject to the following two conditions:

- 1) This device may not cause interference.
- 2) This device must accept any interference, including interference that may cause undesired operation of the device.

This equipment must be installed and operated in accordance with provided instructions and the antenna(s) used for this transmitter must be installed to provide a separation distance of at least 20 cm from all persons and must not be co-located or operating in conjunction with any other antenna or transmitter. End-users and installers must be provided with antenna installation instructions and transmitter operating conditions for satisfying RF exposure compliance.

### IC Warning:

This transmitter must not be co-located or operating in conjunction with any other antenna or transmitter. This equipment should be installed and operated with a minimum distance of 20 centimeters between the radiator and your body.

### Wireless Transmitter:

Transmitter and WiFi Characteristics = RF OdBM/2402-2480 MHz



# Operating Instructions

## SEAR ON THE HOPPER LID / SEAR PLATE

You can also use your hopper lid for high-heat searing.

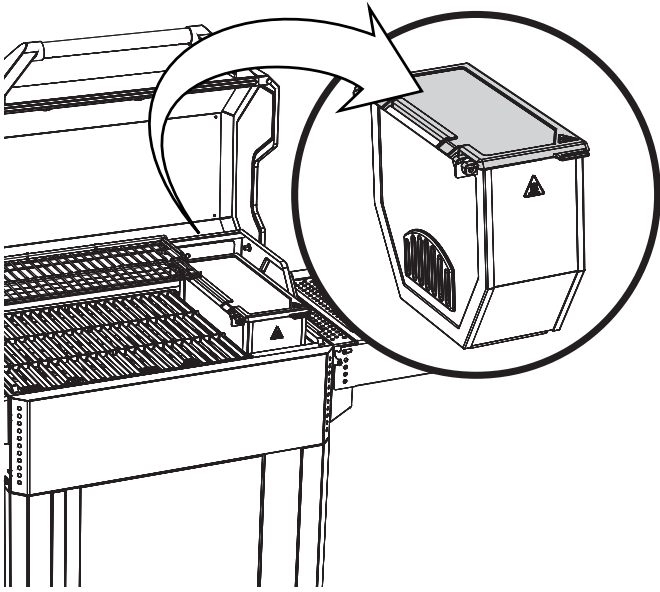

## WARMING RACK

Lift and slide back for more grill space.

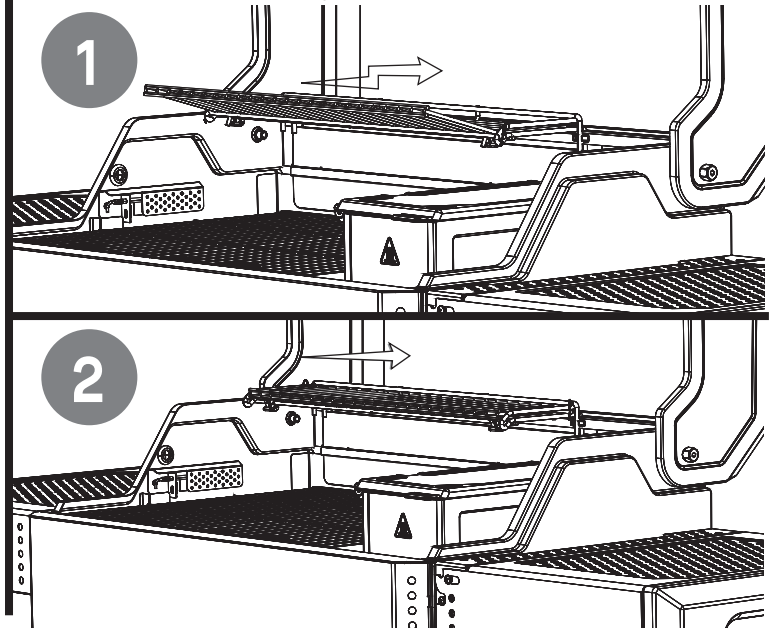

## CLEANING AND STORAGE

**ALWAYS MAKE SURE GRILL IS COOL TO THE TOUCH BEFORE CLEANING AND STORING.**

- Once ashes have completely cooled, empty the charcoal hopper of ash after each use. This will help prolong the life of the charcoal hopper.
- Dispose of cold ashes by placing them in aluminum foil, soaking with water and discarding in a non-combustible container.
- Remove the charcoal grate and clean.
- Remove the cooking grates and manifold to clean.
- Remove grease cup and heat tent to clean.
- Remove hopper lid (sear plate) and clean. The hopper lid is coated cast iron, please wipe clean with a damp rag, for stuck on debris you may need to rub with a non-abrasive scrub brush. Once clean, apply a light coating of oil to the sear plate to prevent rust. If rust occurs on the sear plate, clean with a steel brush, apply vegetable shortening and heat the grill as noted in the seasoning instructions.
- Inspect hardware and assembled parts on a regular basis to ensure grill is in safe working condition.
- Clean grill and cooking grates with mild dish detergent. Wipe outside of grill with a damp rag. **DO NOT** use oven cleaner or other cleaning agents. Make sure to dry thoroughly.
- Wipe down with cooking oil to avoid rusting
- Always cover and store grill in a protected **DRY AREA**. Store only when fire is out and all surfaces are cold.
- When grill is not in frequent use, even when using a grill cover, remember to check your grill periodically to avoid possible rust and corrosion due to moisture buildup.

### NOTE:

**WARNING!** Do NOT store combustible materials under the grill or in the grill cabinet. Hot ash can reach the grill cabinet. Use caution.

# Troubleshooting

SYMPTOM	CAUSE	POSSIBLE SOLUTION
Controller not ON.	Power not ON.	Press the power button on the controller.
	Not plugged in.	Plug controller into power supply and power supply into wall outlet.
	Circuit breaker tripped.	Check wall outlet circuit breaker and reset if tripped.
	Controller malfunction.	Masterbuilt Customer Service <a href="https://www.masterbuilt.com/pages/support">https://www.masterbuilt.com/pages/support</a>
Fan not ON.	Temperature in cabinet has reached the set temperature.	Once the set temperature is reached the fan will turn off. Once the temperature falls below the set temperature the fan will restart. The fan will continue adjusting itself automatically to maintain the set temperature.
	Fan disconnected from controller.	Check that connection is fully seated.
	Fan disconnected from wiring harness.	
	Err 3	See below.
Controller temperature inaccurate.	Temperature probe not fully plugged in.	Check that connection is fully seated.
	Temperature probe is dirty.	Carefully clean temperature probe.
Slow heating.	Low charcoal.	Refill hopper with charcoal.
	Grill lid open.	Close grill lid.
	Fan not on.	See "Fan not ON."
Igniter will not ignite or slow to ignite.	Igniter will not operate if grill temperature is above 200F / 93 C	1. Ensure the igniter has no debris or obstructions. 2. Ensure that the firestarter and tray are fully inserted and touching the igniter. Err6: See Below.
Poor Wifi connection	Weak signal.	1. Angle the antenna on back of controller to point at the ground
Controller restarts, enters standby mode.	Electrostatic charge. When the product is disturbed by electrostatic discharge, the controller may restart, then enter standby mode.	Controller needs to be restarted by the user to restore normal operation, this phenomenon is normal.
Err 1	Temperature probe not fully plugged in.	1. Check that connection is fully seated. 2. Unplug controller from power supply, wait 10 seconds and reconnect.
Err 2	Meat probe malfunction.	Masterbuilt Customer Service <a href="https://www.masterbuilt.com/pages/support">https://www.masterbuilt.com/pages/support</a>
Err 3	Grill overheated.	1. Turn off grill. 2. Check for cause of overheat. • Grease fire. • Fan malfunction. 3. Restart grill.
Err 4	Charcoal failed to ignite.	1. Ensure hopper lid and lower hopper door are fully closed. 2. Ensure charcoal is not empty. 3. Ensure no old ash remains from previous use. 4. Fill hopper with charcoal before inserting firestarter. 5. Ensure the Ignition button was pressed and Igniter is working 6. Restart grill.
Err 5	Meat Probe Temp above 300°F.	1. Using protective gloves, remove meat probe from grill. 2. Unplug from controller. 3. Allow meat probe to cool.
Err 6	Igniter malfunction	1. Turn off Grill 2. Unplug and Check connection of igniter 3. Restart Grill and Press the Igniter Button 4. Contact Customer Service if error persists 5. Check for debris on top of the igniter

## LIMITED WARRANTY

Masterbuilt® warrants all of its products to be free from defects in material and workmanship under proper assembly, normal use and recommended care for 1 year from the date of original retail purchase. The Masterbuilt® warranty does not cover paint finish as it may burn off during normal use. The Masterbuilt® warranty does not cover rust. Masterbuilt® requires proof of purchase for warranty claim, such as a receipt.

EUROPEAN RESIDENTS ONLY: Masterbuilt® warrants all of its products to be free from defects in material and workmanship under proper assembly, normal use and recommended care for 2 years from the date of original retail purchase

## WHEN DOES THE WARRANTY COVERAGE BEGIN?

Warranty coverage commences on the original date of purchase and covers only the original purchaser. For the warranty to apply, you must register your grill. If a defect in material or workmanship is discovered during the applicable warranty period under normal use and maintenance, Masterbuilt® will, at our sole option, replace or repair the defective component at no cost to you for the component itself. This warranty does not apply to labor, or any other cost associated with the service, repair or operation of the grill. Masterbuilt® will pay all shipping charges on warranty parts.

AUSTRALIA AND NEW ZEALAND RESIDENTS ONLY: Our goods come with guarantees that cannot be excluded under the Australian or New Zealand Consumer Law. You are entitled to a replacement or refund for a major failure and compensation for any other reasonably foreseeable loss or damage. You are also entitled to have the goods repaired or replaced if the goods fail to be of acceptable quality and the failure does not amount to a major failure.

## WHAT IS NOT COVERED?

This warranty does not apply to damage caused by abuse or use of the product for purposes other than that for which it is designed, damage caused by lack of proper use, assembly, maintenance or installation, damages caused by accidents or natural disasters, damage caused by unauthorized attachments or modifications, or damage during transport. This warranty does not cover damage from normal wear and tear from use of the product (for example, scratches, dents, dings and chipping) or changes in the appearance of the grill that do not affect its performance. Commercial use is not recommended with the use of Masterbuilt products, and this warranty does not apply to commercial use of any kind. This usage for example is for restaurateurs, caterers, butchers, rental companies, food trucks and other such commercial entities. This limited warranty is exclusive and in lieu of any other warranty, written or oral, express or implied, including but not limited to the warranty of merchantability or fitness for a particular purpose. The duration of any implied warranties, including any implied warranty of merchantability or fitness for a particular purpose is expressly limited to the duration of the warranty period for the applicable component.

The purchaser's exclusive remedy for breach of this limited warranty or any implied warranty shall be limited as specified herein to replacement. In no case shall Masterbuilt be liable for any special, incidental or consequential damages.

This warranty is provided to you in addition to all rights and remedies conveyed to you by consumer protection laws and regulations. This warranty in no way affects your legal rights under statutory warranty regulations in your state or country of residence, including the EU. Depending on your state or country of residence limitations on the length of an implied warranty or the damages available to you may not be limited by this warranty.

## WHAT WILL VOID THE WARRANTY?

Purchasing any Masterbuilt® product through an unauthorized dealer voids the warranty. An unauthorized dealer is defined as any retailer who has not been expressly granted permission by Masterbuilt® to sell Masterbuilt® products.

## NEED ASSISTANCE? CONTACT US

Our warranty terms may change from time to time. For an updated version of our warranty, visit [www.masterbuilt.com/pages/warranty](http://www.masterbuilt.com/pages/warranty). For assistance or to request an updated copy of our warranty, contact us at the below.

### Masterbuilt®

#### Premier Specialty Brands, LLC

5367 New Peachtree Road

Suite 150

Chamblee, GA 30341

<https://www.masterbuilt.com/pages/customer-support>

### Masterbuilt®

#### Kamado Joe Europe

Lange Voorhout 86

2514 EJ Den Haag

Netherlands

<https://international.masterbuilt.com/pages/customer-support>

### Australia & New Zealand

Please contact your retailer.

### Masterbuilt®

#### Kamado Joe UK Limited

Cheyenne House West Street

Farnham GU9 7EQ

<https://international.masterbuilt.com/pages/customer-support>

**MASTERBUILT®**